



Goff's Enterprises, Inc.

Manufacturers of the Original Goff Curtain Walls
 1228 Hickory Street • Pewaukee, Wisconsin 53072
 Phone 800-234-0337 • 262-691-4998 • Fax 262-691-3255
 Email sales@goffscw.com • Web www.goffscurtainwalls.com

Mounting and Assembly Instructions Manual Roll-Up Curtain

System Overview:

Your Goff's Manual Roll-Up Curtain is a high quality, high performance flexible partitioning system based on proven components and our many years of experience in the vinyl partition fabrication business. We are confident that it will bring you and/or your customers years of reliable and trouble-free service.

Unpacking and Inspection:

Please unpack your unit carefully and notify the factory immediately if there are any shortages or if any items have been damaged during transit. Your kit(s) should have all of the necessary hardware and components for a complete installation with the following exceptions (installer-provided hardware):

1. Mounting hardware for securing the L-Brackets to the building or support structures.

Assembly and Mounting:

Your kit contains the hardware identified in the following diagram (Diagram #1). Please familiarize yourself with the components and their function.

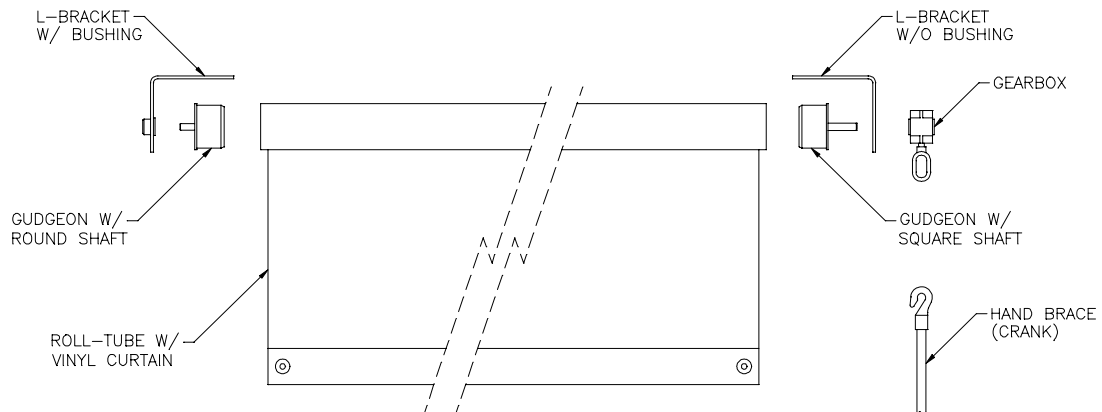

Diagram #1
 (Kit Components)

Note that the gearbox can be mounted on either side (left or right) of the roll-tube, and that the L-Brackets can be configured with the “ears” pointing inward or outward. Orientations with the ears pointing inward may make it difficult to access the bracket mounting fasteners. The following diagram (Diagram #2) depicts a few of the typical configurations:

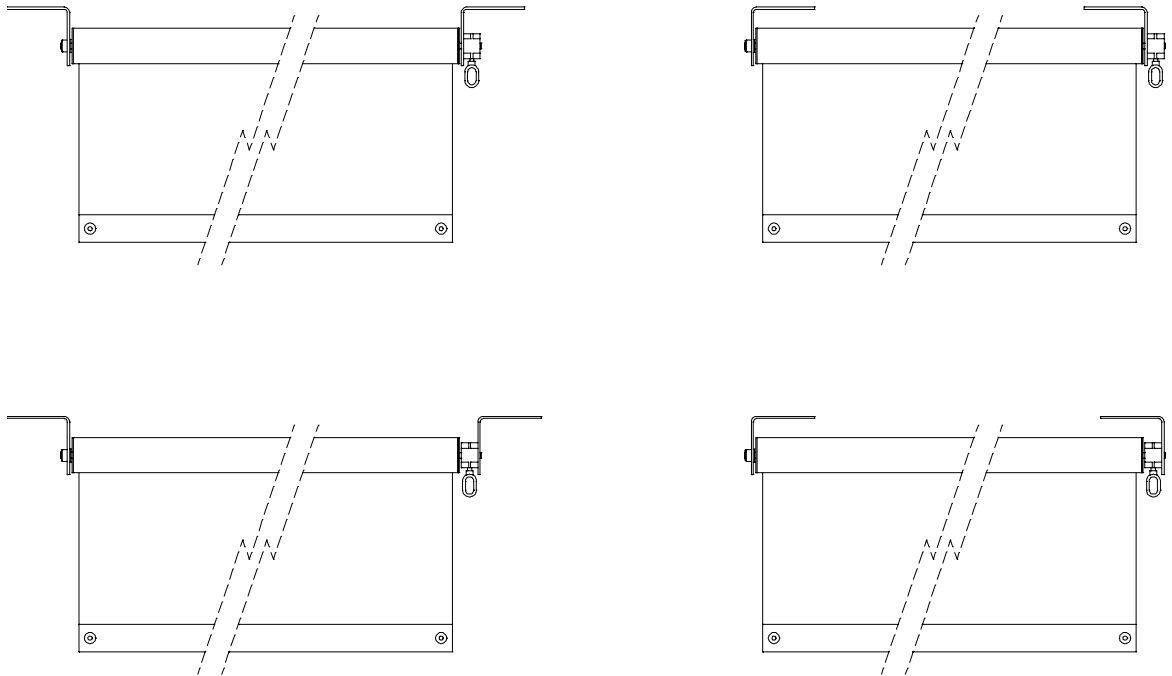

Diagram #2
(Bracket and Gearbox Typical Configurations)

The L-Brackets can be mounted to vertical or horizontal surfaces providing they have enough strength to properly support the assembly and withstand any forces generated by its actuation. The unit can be configured so that the curtain “waterfalls” toward the wall or away from it. The gearbox can be mounted in 45° increments on the L-Bracket in order to provide easy access to the drive ring, and it can be “flipped” on the bracket in order to provide clockwise or counter-clockwise operation. Please see the following diagram (Diagram #3) for a few examples:

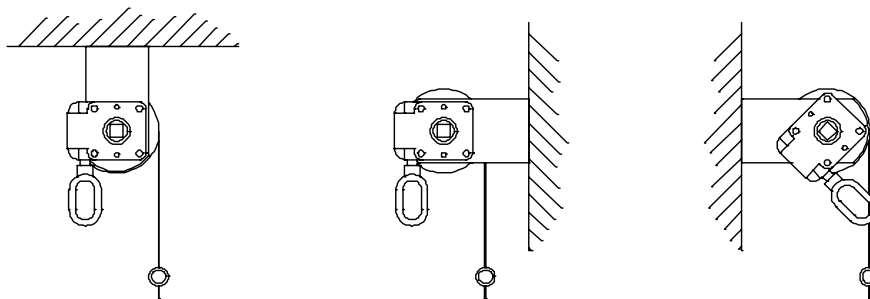

Diagram #3
(Bracket and Gearbox Typical Configurations)